

JoinMesh Baby Carrier Instruction Manual



When using this product for more than 3 years, materials may deteriorate causing unexpected danger. Do not use it to avoid any unexpected accident.

CAUTION

- Please thoroughly read this manual before and use the product accordingly. Otherwise such a misuse may injure baby.
- Please keep this manual in a convenient place for ease of future reference.
- If you pass this product to others, please make sure to attach this manual to the product.

Before use

Thank you for purchasing Join Baby Carrier. This product is a generic single-baby carrier designed for cuddling or back carrying a baby during shopping or outdoor activities. Before use, please read “Name of all parts” on P.5 and check out the parts accordingly.

- Read all instructions before assembling and using the carrier. Keep instruction for future use.

■ Age reference for applicable baby

Carrying style	Age reference					Weight
	Neck muscle developed (0 month)	Neck muscle developed (4 months)	Neck muscle developed (7 months)	24 months	36 months	
Rear facing cuddling			Neck muscle developed ~ 24 months			Up to 13kg
Back carrying			Neck muscle developed ~ 36 months			Up to 15kg
Side carrying			Neck muscle developed ~ 24 months			Up to 13kg



- Some large babies may not fit the carrier in winter months when wearing thicker clothes.
- Please choose clothes for baby carefully before using the carrier.
- Waist pad maximum size is 120cm.

For safe use of our product

Caution about safety

The caution items mentioned here are about how to use the product properly and safely so as to prevent any possible injury to user and baby and any damage to the product. Moreover the caution items are categorized according to the degree of injury and damage to the product which are indicated as “warning” and “caution” respectively.

Caution and usage conditions mentioned are very important. Please read and follow accordingly.

 WARNING	Improper operation may directly cause death, severe damage or injury.
 CAUTION	Improper operation may cause injury or damage to the product.

Details of the caution item is written inside the frame (P.2~4)

 This sign indicates a warning or caution item.

⚠ WARNING

[Fixation]

Always secure the following buckles when use. Otherwise baby may fall from the carrier.

• Rear facing cuddling

- Hold buckle
- Shoulder buckle (left and right)
- Support buckle
- Waist belt buckle

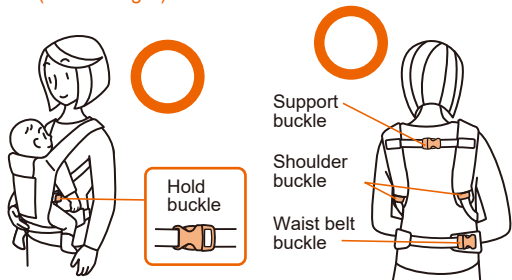

• Back carrying

- Hold buckle
- Shoulder buckle
- Support buckle
- Waist belt buckle

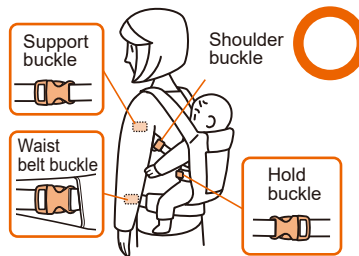

• Side carrying

- Hold buckle
- Waist belt buckle
- Shoulder buckle

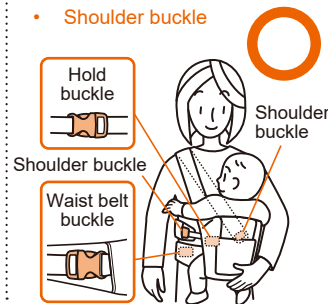

[Adjust]

Please ensure the following belts are comfortably tightened to user's body. Any gap in between baby and user on imbalanced length of the left and right belt may cause baby to fall from the carrier.

• Rear facing cuddling

- Support buckle
- Side belt (left and right)
- Hold buckle
- Waist belt

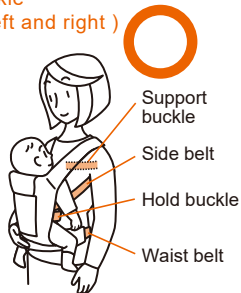

• Back carrying

- Support buckle
- Side belt (left and right)
- Hold buckle
- Waist belt

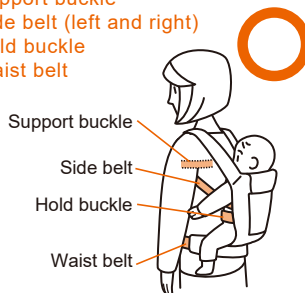

• Side carrying

- Side belt (the shoulder side, the waist side)
- Hold belt
- Waist belt

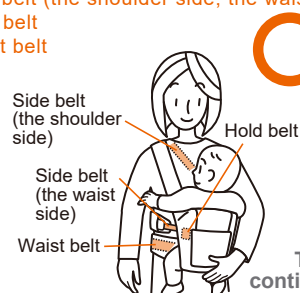

To be continued ➔

! WARNING

It might lead to an unexpected accident such as falling out from an opening or suffocation please adjust and secure all the components.

Please carry and put down the baby at a safe place such as sofa, bed, or the floor, with a lower posture while supporting it by hand.



When the carrier is in use, please do not run, jump, lean forward more than 45 degrees, or lean to the side. Otherwise, baby may accidentally fall from the carrier. Make sure to crouch down with bending knee and hold the child when picking up things from the floor.



In cradling or cuddling position, always support baby with your hands. The baby's unexpected movement may cause it to fall from the carrier.



Pay attention if baby's face is too close to user's chest, or baby's neck is bent, this may affect baby's airway and makes it difficult to breathe.



Do not re-modify or improper repair the product. Otherwise, it may damage the product and may cause accident.



Cuddling and back carrying is not applicable to baby whose neck muscles are not yet developed, otherwise the baby may become tired, exhausted or cause injury.

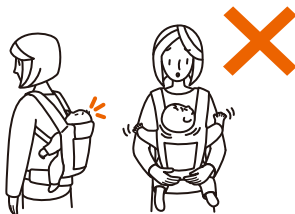

In cuddling or back carrying position the waist pad should be under the baby's legs. Otherwise, it may press against baby's legs.



Please do not put any sharp things into the pocket. Baby might bear an injury.



In cuddling or back carrying position, if baby's armpit presses against the carrier sheet, adjust the baby's position (refer to p.22). Otherwise, unexpected burden or injury may be inflicted to baby.

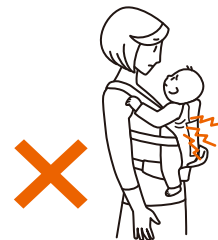

! CAUTION

Please do not use it on vehicles other than train, bus and high-speed railway. Baby might fall by unexpected movement.



Do not use the carrier continuously for more than 2 hour, or within 30 minutes after feeding. Otherwise, the baby or user may experience discomfort.



Check baby's conditions regularly, stop using the carrier at once if any abnormal facial expression from baby is seen.



Stop using the carrier immediately if you experience pain or discomfort.



When using in the cuddling position, please watch your step.



When doing the housework, pay enough attention not getting hurts from the kitchen knife, burns from the stove and falls from bending forward.



In the event that any damage to the product is found, cease using the carrier immediately.

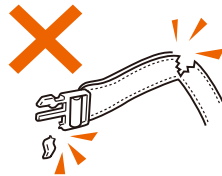

Do not leave the carrier near fire or outside. Otherwise, buckles or other fabric parts may be deteriorated by heat or rain which may become cause of accident.



Do not use this product for the purposes other than those stated in this manual to avoid any damage to the product.



Do not let the baby place their fingers into an unfastened buckle as they may become stuck and cause injury. Please fasten the buckle even if you are not using the product.



Name of all components

Carrier (the body)

Outer side

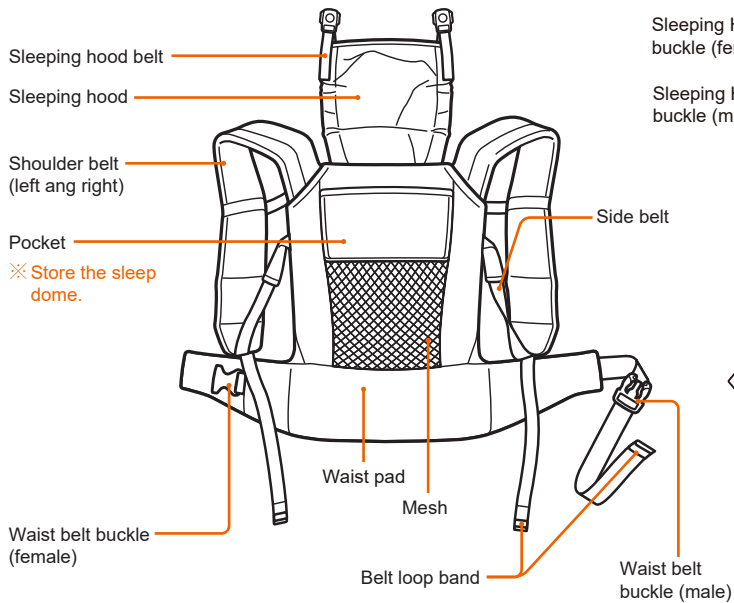

Inner side

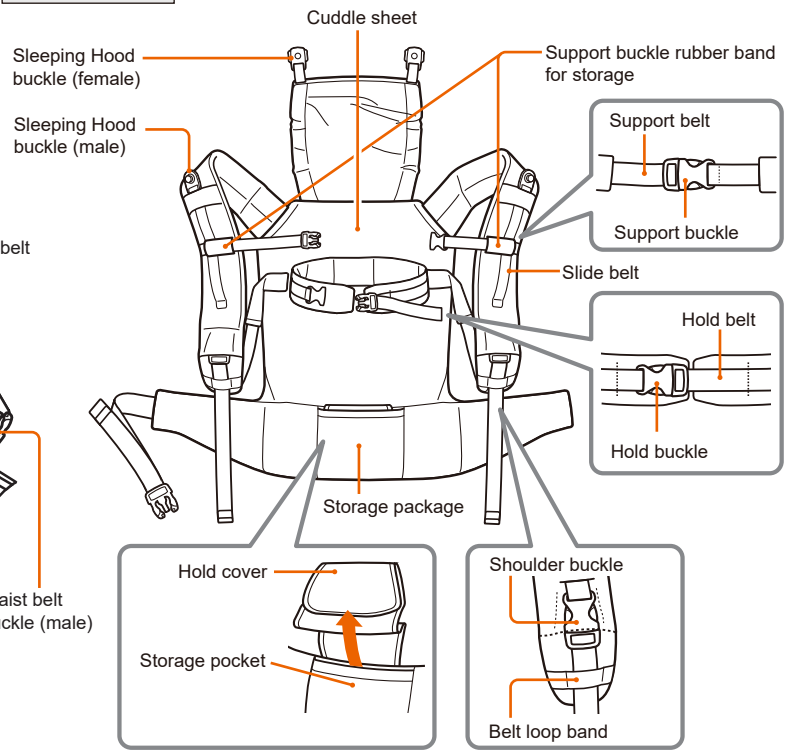

Preparations before putting on

Adjust the length of the belt before putting on

Please adjust all belt length before putting on. The position of the belt as shown in below. Ensure the waist pad fits to the user by adjusting the length of waist belt. Adjust the height of support belt.

- Move the left and right support belt up and down along the slide belt to adjust to the same height. (Refer to Figure A)

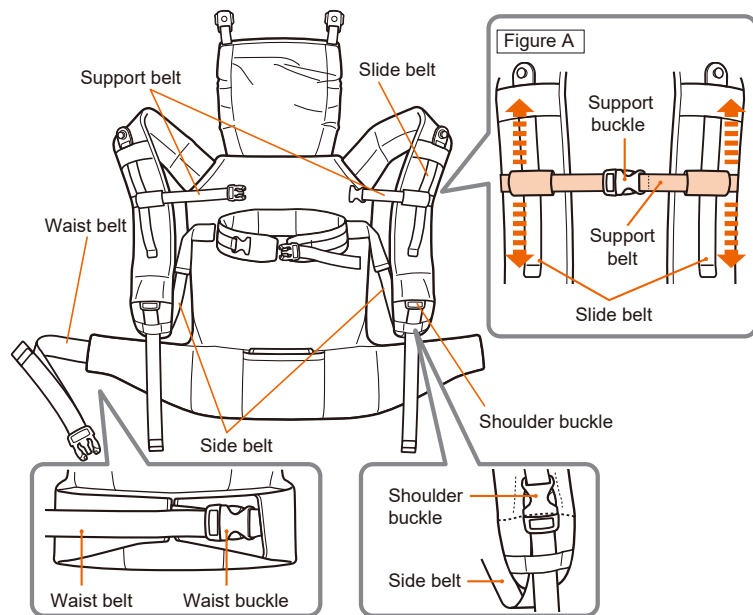

Belt length adjustment methods

Adjust the length of belt as shown below.

※ Here is an illustration to describe the side belt.

- To shorten, pull out the excess of belt

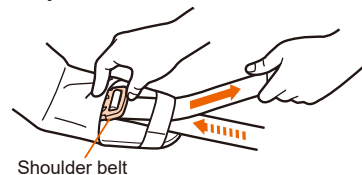

- To lengthen, lift the ladder lock vertically and pull back the belt

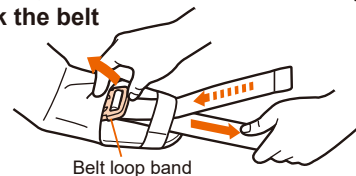

When pulling the belt, lift the ladder lock vertically as shown in the illustration. The belts are adjustable during cuddling.

⚠ WARNING

If there is too much gap between user and the baby, or the length of the left/right belts are different, the baby may fall down by unexpected movement.

When using as rear facing cuddling (Place the baby before putting on carrier)

Put on ※ Place the baby before putting on carrier

Fasten the hold buckle and carry baby after placing the baby onto the infant sheet.

1 Fasten waist belt buckle

Fasten waist belt buckle until a “click” sound is heard.

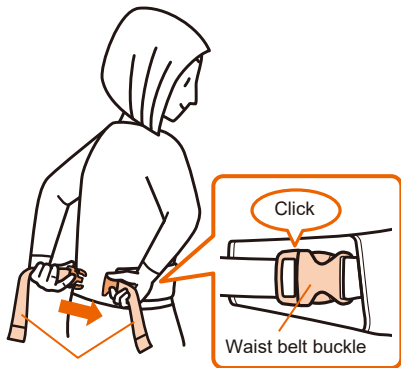

2 By adjusting the waist belt, make the carrier facing to the front

Please see [part adjustment methods] (page 6) for the adjustment of waist belt.

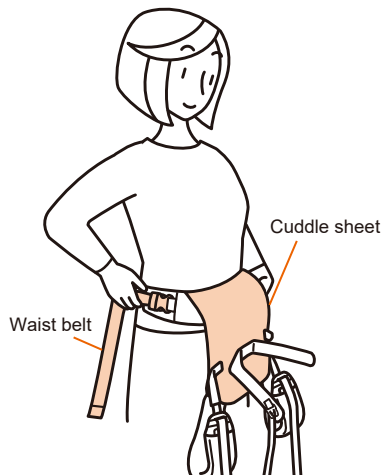

3 Open the carrier widely at the safe place, lay the baby down to the carrier by supporting the neck.



Point



To reduce the burden, it is recommended to wear the waist pad at the lower waist around the hip. User should adjust it to his/her comfortable position.

Excess length of waist belt can be folded and tied using the belt loop band as shown in the illustration.

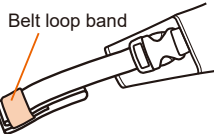

⚠ WARNING

Carry out and place a baby in a safe place such as sofa, bed or the floor, always support with hand and putting down in low posture.

4 Secure the hold buckle, and adjust the length of the belt

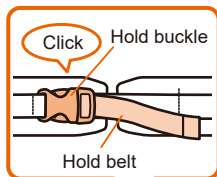

! WARNING

Ensure hold buckle is secured. Otherwise, baby may fall from the carrier.

5 Support the child by hand while putting on the shoulder belts

Shoulder belt

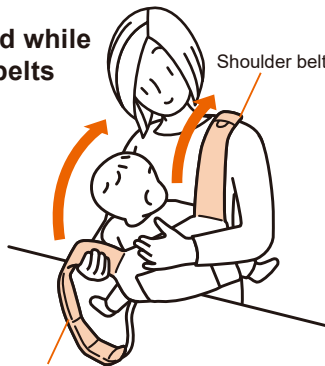

! WARNING

Should support the baby by hand when putting on; otherwise, the baby may fall down.

Shoulder belt

6 Secure the support buckle behind the neck

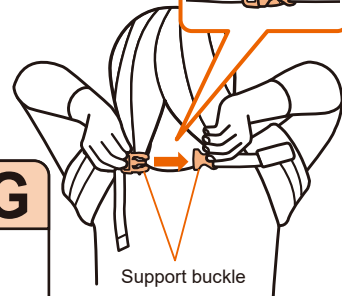
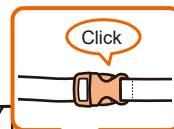

! WARNING

Please secure the support buckle with caution when putting the baby on; otherwise, the baby may fall down.

Support buckle

7 Adjust the side belt and make it fit to the user's body

The remainings of the side belt can be put together and tie with the belt band as shown in figure.

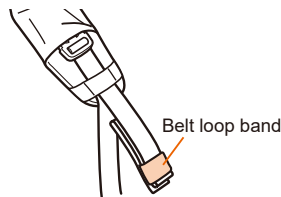

Side belt

When using as rear facing cuddling (Put on carrier before placing the baby)

Put on ※ It is better to place the baby before putting on carrier.

Put on the carrier first, carry the baby in the arm and secure the hold buckle.

- 1 Fasten waist belt buckle**
Fasten waist belt buckle until a “click” sound is heard.

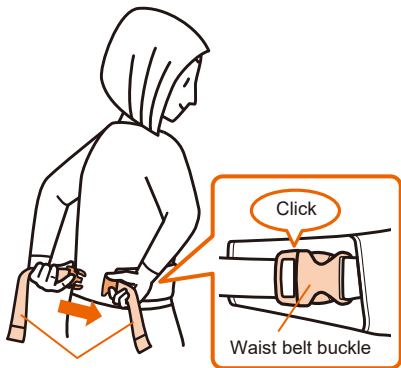

- 2 By adjusting the waist belt, make the carrier facing to the front.**
Please see [Preparation before wearing] (page 6) for the adjustment of waist belt.

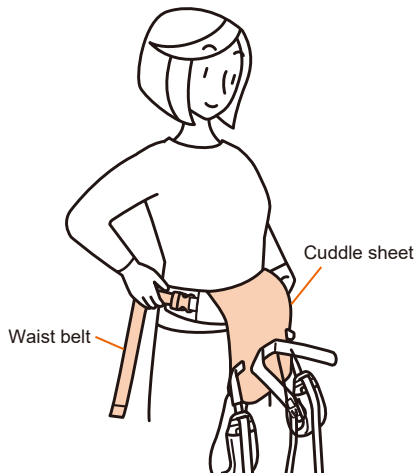

- 3 Put the baby onto the carrier while supporting the baby's neck.**



Point

To reduce the burden, it is recommended to wear the waist pad at the lower waist around the hip. User should adjust it to his/her comfortable position.

Excess length of side belt can be folded and tied using the holding band as shown in the illustration.

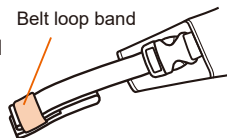

WARNING

Carry out and place a baby at in a safe place such as sofa, bed or the floor, always support with hand and putting down in low posture.

4 Support the baby by hand while putting on the shoulder belts

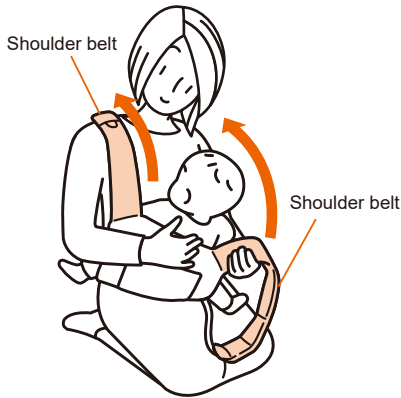

5 Secure the support buckle

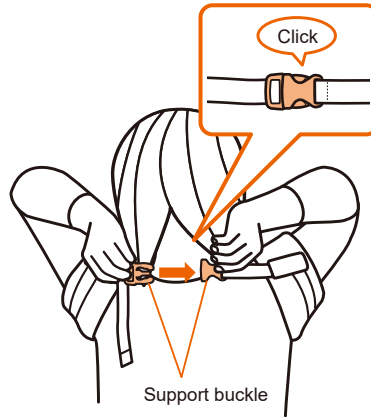

6 Secure the hold buckle, and adjust the length of the belt



! WARNING

Should support the baby by hand when putting on, otherwise, the baby may fall down.

! WARNING

Please secure the support buckle with caution when putting the baby on, otherwise, baby may fall down.

! WARNING

Ensure hold buckle is secured. Otherwise, baby may fall from the carrier.

When using as rear facing cuddling (Put on carrier before placing the baby)

7 Adjust the length of left and right side belts to fit user's body

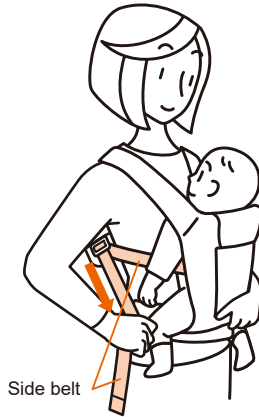

Side belt



Excess length of side belt can be folded and tied using the belt loop band as shown in the illustration.

Belt loop band

Check the wearing status

Ensure the join carrier position are appropriate by checking the following check points in the mirror.

Check ✓ point



- Is the hold buckle secured?
- Is the baby's underarm, thigh or back of the knee being pressed?

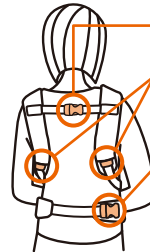

- Is the support buckle secured?
- Is the shoulder buckle secured?
- Is the waist buckle secured?
- Is the length of each belt adjusted to fit the user's body?

! WARNING

- Fail to ensure the check points may
- cause the baby to fall from the carrier.
 - impact the baby's breath, or cause other injuries.
 - impact the blood circulation to the arms or legs.

! CAUTION

Ensure your visibility is not impaired by the position of the baby's head. Please mind your step as it maybe difficult to see your feet.

How to release the rear facing cuddling

Release method shown as below, please remove it at a safe place.

- 1 ① Release the support buckle while supporting the baby.
② Release the left/right shoulder belts.

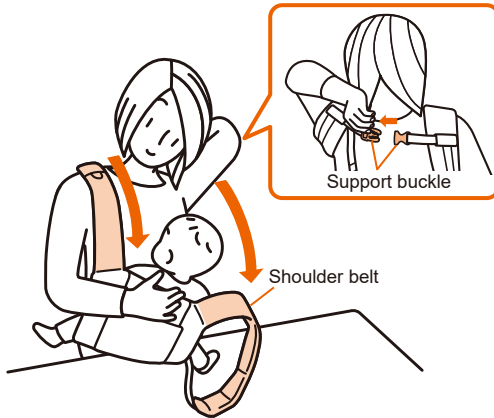

⚠ CAUTION

As the shoulder belt may come off suddenly when removing the support buckle, please remove it with caution.

- 2 Release the hold buckle, and put down the baby.

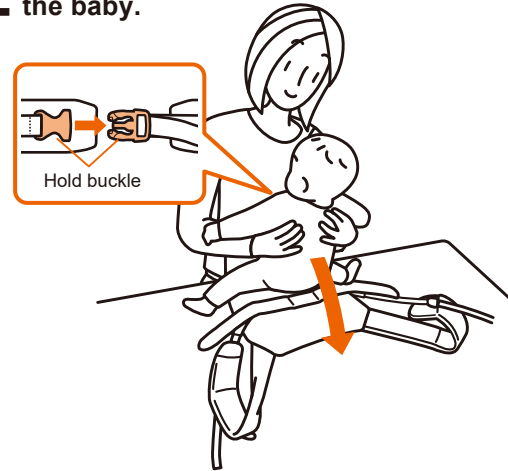

- 3 Release the waist buckle

⚠ WARNING

Carry out and place a baby at a safe place such as sofa, bed or the floor, always support with hand and putting down in low posture.

How to use for back carrying

Put on

1 Seat baby into carrier

- ① Place the child on the carrier, and pass the hold belt through the hold cover as shown in diagram.
- ② Fasten the hold buckle, and adjust the length of the belt.

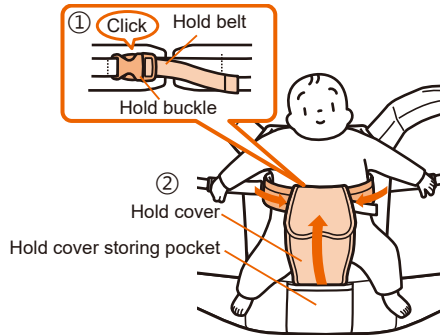

2 Carry baby

- ② When standing up with a baby carrier on back, securely hold the end of shoulder belts where it joins the carrier body.

Securely hold the end of shoulder belts where it joins the carrier body.

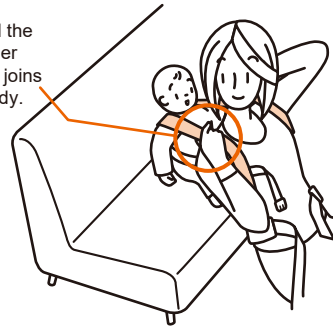

3 Fasten support buckle

- ③ Adjust the length and height of support belt.

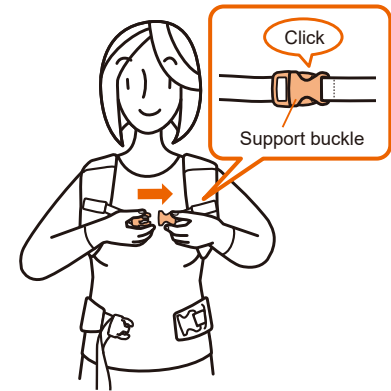

! WARNING

Seat baby into carrier at a safe place. (It is recommended to have another person assist the operation). Seating or unseating baby at an unsafe place may cause baby to fall from the carrier. Ensure hold buckle are secured. Otherwise, baby may fall from the carrier

It is recommended to have another person assist the operation.



! CAUTION

Adjust the height of support buckle, if you feel pain or discomfort. If you still experience pain or discomfort, stop using the carrier immediately.

4 Fasten the waist belt buckle

Fasten the waist belt buckle until a "click" sound is heard.

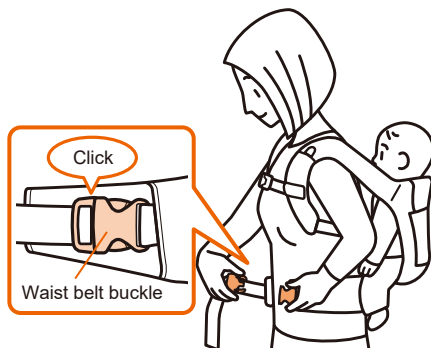

5 Adjust the side belt to fit user's body

Adjust side belts such that left and right belt ends are the same length. Please see [Belt length adjustment methods] (page 6) for the adjustment of waist belt.

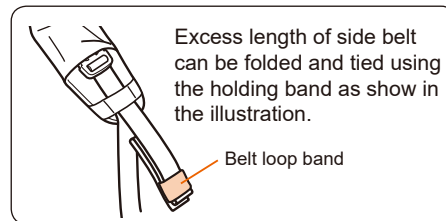
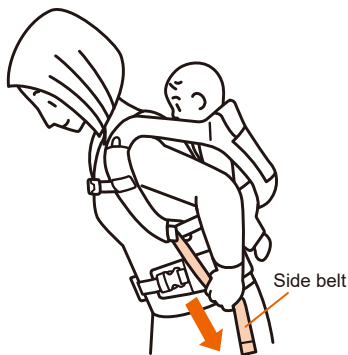

⚠ CAUTION

The waist pad should be under the baby's legs. Otherwise, it may affect the blood circulation to baby's thigh.



➡ Regular check "After putting on" please refer to Page 15. When back carrying, check baby's condition every half an hour.



In back carrying position (especially for younger babies), as user is unable to see the baby, please try to unload baby every 30 minutes and check its condition.

Check the status

Check the status

Ensure the carrier is correctly fitted by checking below points in the mirror.



Check ✓ point

- Is the hold buckle secured?
- Is the baby's underarm, thigh or back of the knee being pressed?

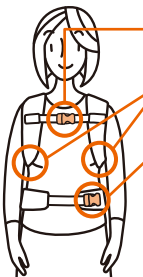

- Is the support buckle secured?
- Is the shoulder buckle secured?
- Is the waist buckle secured?
- Is the length of each belt adjusted to fit the user's body?

WARNING

- Fail to ensure the check points may
- cause the baby to fall from the carrier.
 - impact the baby's breath, or other injuries.
 - impact the blood circulation to the arms or legs.

How to release back carrying

- 1 Release support buckle, and waist pad.
- 2 Unload baby from the back.
 - ※ It is recommended to have another person assist the operation.

Hold the end of shoulder belts where it joins the carrier body.

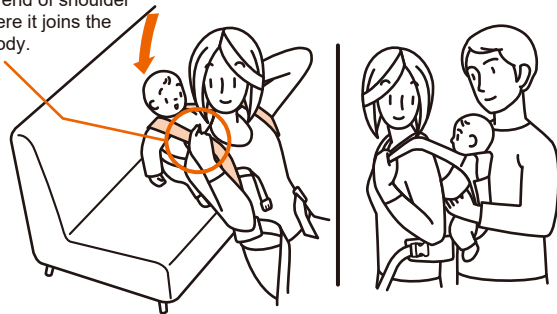

- 3 Lay the baby down at a safe place, and release the hold buckle and hold cover.

WARNING

Carry out and place a baby at a safe place such as the floor, sofa or bed, always support by hand and putting down in lower posture.

How to use the sleeping hood

When using face in cuddling, it can support the child's head in case of falling asleep. It can also be used as a wind-break or a sunshade.

- ※ Do not use the sleeping hood if infant sheet is being used (Selling separately).
- ※ Do not use the sleeping hood if side carrying is being used.

Using the sleeping hood

Please use the sleeping hood properly while rear face cuddling and back carrying.

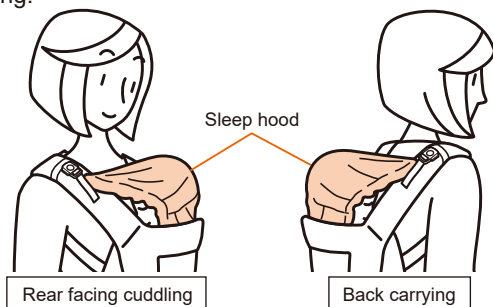

How to adjust the length of the sleeping hood belt

According to a child growth, please adjust the length of the hood belt.

- To shorten, pull out the excess of belt.
- To lengthen, lift up the buckle and pull back the belt.

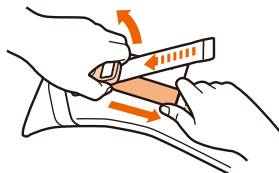
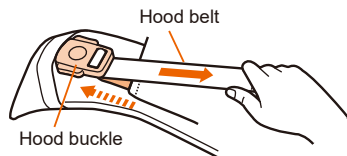

When the belt is hard to pull, lift up the buckle and pull down as shown in diagram.

Installing

When installing, push and fasten from the hood buckles (female) to shoulder belt of hood buckles (male) until "click" sound is heard.

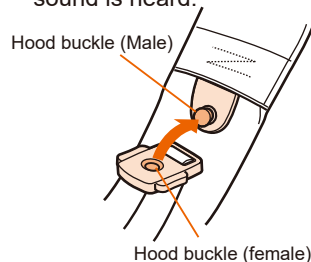

Detaching

To loosen by pressing the release buttons of the left and right hood buckles (female).

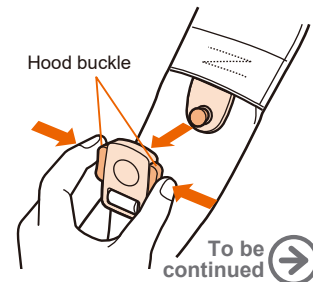

! WARNING

- Pay attention to the baby in case of the sleeping hood is being used. The airway may be blocked to cause suffocation.
- Please stop using the sleeping hood in case it is too tight to be used.
- Baby may get injured if put an unexpected burden on the body.

How to use the sleeping hood

When not using the sleeping hood

Store the sleeping hood in the pocket

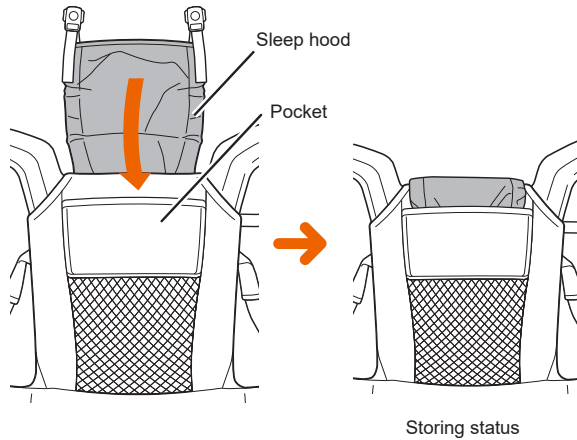

Using for side carrying

Preparations before wearing

- Release the buckle of sleeping hood buckle, and store it in the pocket. (See Page 17) ※ When side carrying is being used, the sleeping hood cannot be used.
- Store the left/right support buckles in the support buckle band.

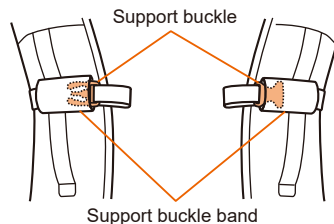

Put on ※ It can be carried in either right or left sides. The explanation here is for left side.

1 Fasten waist belt buckle

Fasten waist belt buckle until a “click” sound is heard.

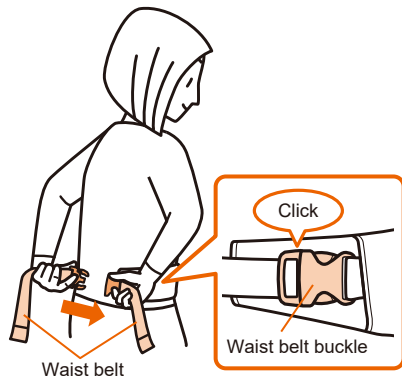

Point



To reduce the burden, it is recommended to wear the waist pad at the lower waist around the hip. User should adjust it to his/her comfortable position.

2 Adjust the waist belt, and release the left and right of shoulder buckles

Please see the method of belt adjustment "Part adjustment methods". (Please refers to the Page 6)

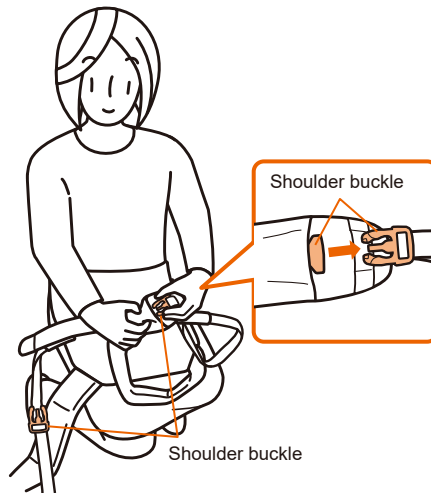

Excess length of side belt can be folded and tied using the holding band as show in the illustration.

Belt loop band

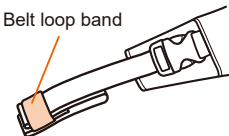

To be continued →

Using for side carrying

3 From the view of user, put the left side belt through the right shoulder belt loop and secure the shoulder buckle

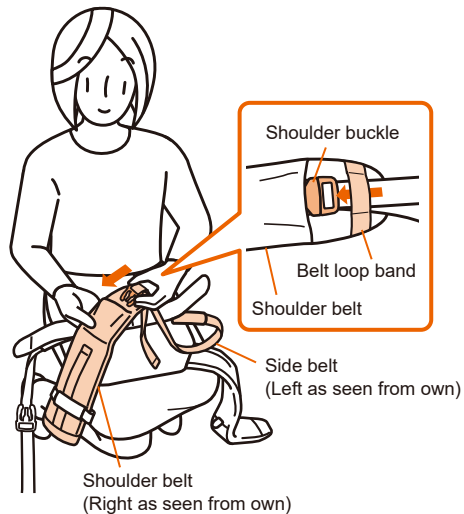

4 Cover the right shoulder with shoulder belt
Please move the carrier to the left.

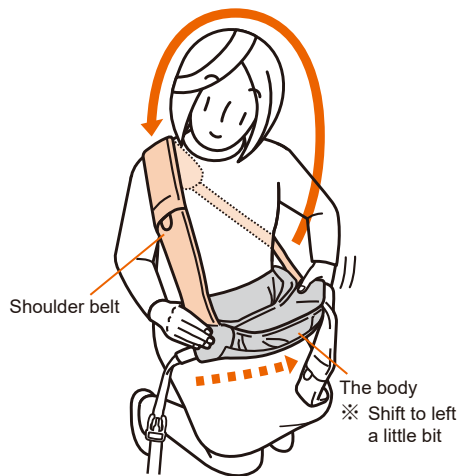

5 Hold the baby, place the baby from the top of carrier and using the hold belt to support.
Please adjust the length of hold belt when supporting the baby by hand.

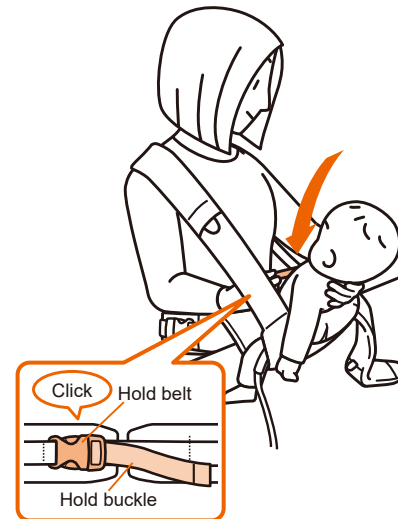

It is much easy to wear if the remaining length of the side belt is adjusted to around 15cm.

! WARNING

- Carry out and place a baby at a safe place such as floor, sofa or bed, always support with hand and putting down in lower posture.
- Please secure the hold buckle. Otherwise, the baby may fall out.

6 Fasten the left shoulder belt into the right side belt buckle from the back around the waist

When fasten the shoulder buckle, please make sure to pass through the belt loop band.

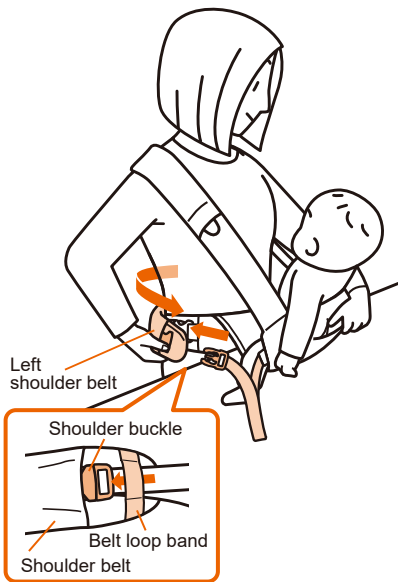

7 Adjust the length of side belt the waist side around.

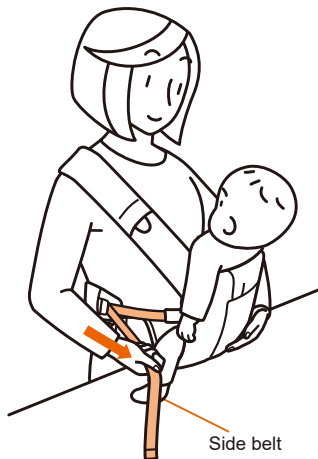

Check the wearing status

Ensure the carrier is securely worn by checking the check points in the mirror.

Check ✓ point

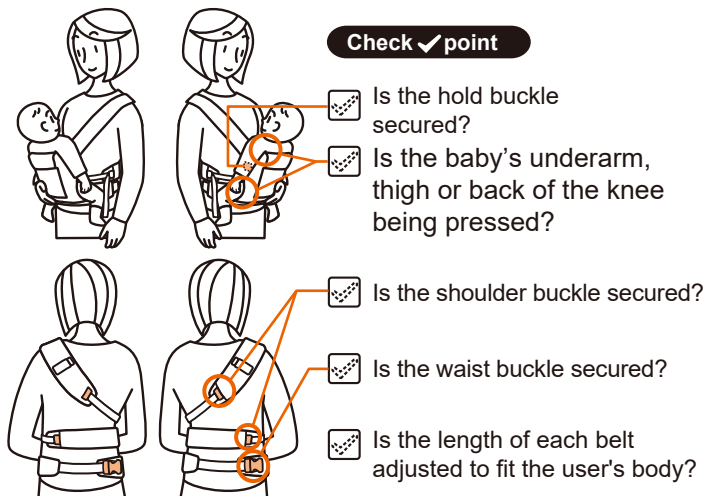

! WARNING

Fail to ensure the check points may

- cause the baby to fall from the carrier.
- impact the baby's breathing, or other injuries.
- impact the blood circulation to the arms or legs.

! CAUTION

Ensure your visibility is not impaired by the position of the baby's head. Please mind your step as it maybe difficult to see your feet.

Using for side carrying

How to use the side carrying

Please remove the side carrying by following steps at a safe place.

1 Release the shoulder buckle which around the user's waist.

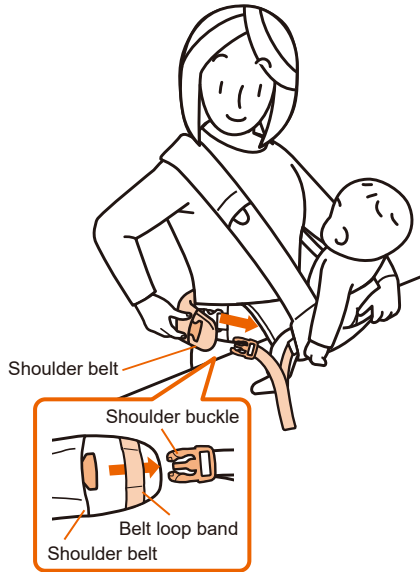

2 Remove the shoulder belt from shoulder

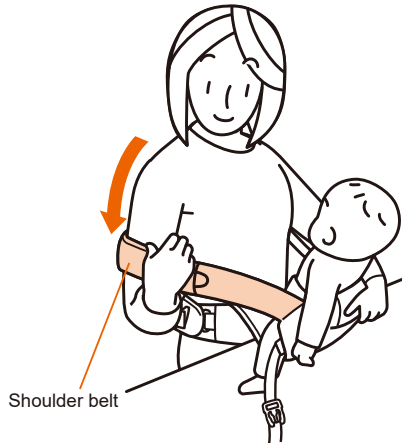

3 Release the hold buckle, and lay down the baby

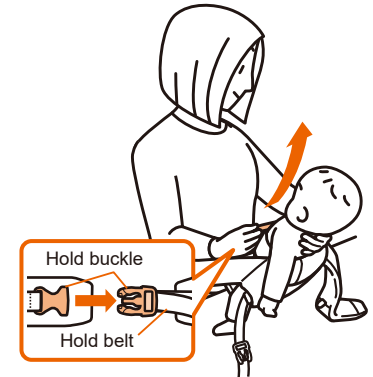

4 Release the waist buckle

! WARNING

Carry out and place a baby at a safe place such as floor, sofa or bed, always support with hand and putting down in lower posture.

Adjust the position of baby

Explain the method of adjusting the baby position after the baby has been carried.

If the side, the thigh, the knee back of baby is pressed by the baby carrier. Adjust the height of the sitting position

Pull the seat downward, please adjust the carrier sheet and the gap between child.

In addition, please adjust the height of the sitting position of the baby by insert a folded towel as shown in below.

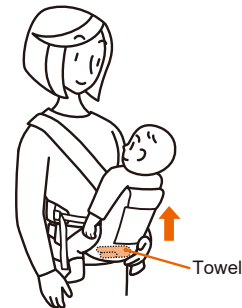
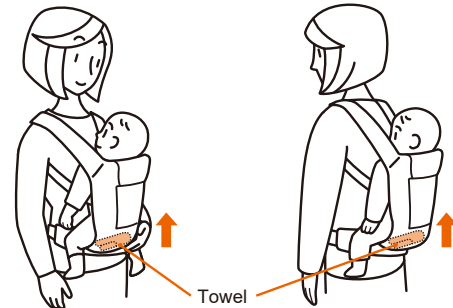
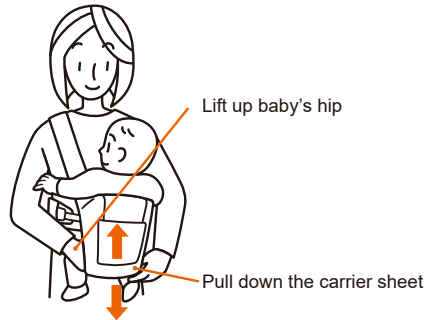
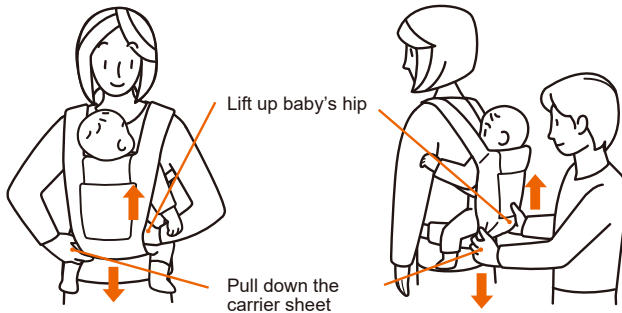

Q In case of the burden of shoulder while having rear facing cuddling, back carrying and side carrying.

A

- Please confirm there is no gap in between the waist belt. Please adjust the belt again if there is a gap.

- Please adjust the sitting position of the child much higher than the waist belt.

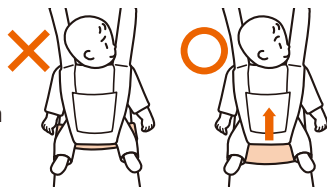

- Please adjust the length of the shoulder belt, the waist belt position, or the position of the child.

▣ About the adjustment method of the position of baby, please see "Adjust the position of the child" (page 22).

Q In case of feeling a gap while having rear facing cuddling, back carrying and side carrying.

A It will be tighter by shortening the side belt .

▣ About the adjustment method of the length of the belt, please see "Part adjustment method", (page 6).

Q In case of the remainings of the side belt being too long while having rear facing cuddling, back carrying and side carrying.

A Side belt can be tied together with belt loop band.

▣ About how to put the side belt together, please see pages 8, 11 and 14.

Q It seems that the baby being hidden while having rear facing in cuddling, back carrying and side carrying.

A The height of the sitting position of the baby can be adjusted by inserting folded towel.

▣ About the adjustment method of the position of baby, please see "adjust the position of the baby" (page 22).

Q In case of a gap between the hip pad and the user's body while having rear facing cuddling, back carrying and side carrying.

A If the hip belt being too loose while having cuddling, back carrying and rear facing, there might be a gap between the user's body. Please shorten the waist belt and prevent forming a gap.

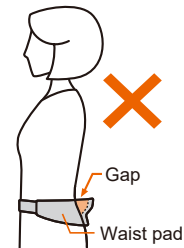

Maintenance

Daily maintenance

- Press washing the carrier in cold or warm water, reshape the carrier, and dry flat in shade.
- Use a damp cloth to clean off small stains.

Caution about washing

- Wash carrier separately from other colored items to prevent color degradation. Do not soak carrier in water for an extended period.
- Do not use bleach or fluorescent brightener as they may cause skin irritation. It is recommended to use detergent series.
- Do not put carrier into washing machine, spinning machine, or drying machine, all of which may cause damage to the buckle.
- Refer to the washing label attached to the product for the appropriate washing methods and carrier composition details.



CAUTION

If fabric is wet from baby's saliva, please clean it as soon as possible to avoid the fabric from becoming hardened. Hardened fabric may inflict discomfort to the baby.

About checking and maintenance

- In case of the use, please confirm whether there is no frayed spot, a cut or a scratch of the product, as well as no damage of the parts (buckle, etc).



CAUTION

When you found even one of the above, please stop using immediately. It might cause failure or an accident.

- Please do not do any remodelling or repairing of the product by self. It might lead to an unexpected accident.
- When using the product and found that there is damage, abnormality, deterioration of the cuddle string, any necessity of replacement or repair of the parts, please stop using. Otherwise, it might lead to a serious accident if insist to use it.
- The colour or specification of the parts is subject to be changed without notice.